

PRIORITIZE MAINTENANCE USING FUZZY LOGIC*

BY

TAPAN SHAH, KHANJAN DEPANI, DEBIRUPA HORE♣

School of Engineering, Ajeenkya D Y Patil University, Pune. 412105, India

ABSTRACT

This project depicts the design and advancement of a Fuzzy Logic-based computerized system for prioritizing industrial machines maintenance work. Our system receives continuous real-time data such as temperature, lubricant level, sound, etc. from the current status of industrial machines. This data is passed on to our innovatively designed fuzzy controller. As an output, we get a priority index for each machine, based on input data and fuzzy logic algorithm. With the help of this priority index, we can schedule the maintenance. This is a user-friendly and easy to setup system that aims to improvise the schedule for maintenance at the industrial level. [1]

KEYWORDS

Fuzzy logic, Prioritize maintenance work.

I.INTRODUCTION

These days the major issue faced by the manufacturing companies, or other related industries is "Maintenance" which includes the maintenance of machines, manufacturing units, accessories, etc. things involved and related to manufacturing. Machines are like humans, even they have to be taken care of. Nowadays due to the limitation of time and funds issues for maintenance, many companies fall short in making a proper schedule for maintenance of their machines. Such issues result in bad product quality and life span shortening of machines. Hence, overall, every industry needs a maintenance system. In which they can get the right information as to what to do and what not to be done. To overcome the issue, we have developed a system known as "Priority-based Maintenance System" It is a MATLAB model-based technique which uses Fuzzy Logic for prioritizing maintenance work that maximizes the return on investment under the constrain of budget and time. Our system receives real-time data from the current status of the machine. This data is passed on to the fuzzy controller. As an output, we get the priority index for each machine. Based on this priority index we can schedule the maintenance.[3][4]

* Received 22 September 2021, Accepted 09 October 2021, Published 24 October 2021

♣ Corresponding Author

II. MATERIALS

A computer/laptop system with minimum of 8 GB ram 250 GB storage, Windows/mac operating system, MATLAB software, Microsoft Excel (for data collection).

III. METHODOLOGY

1. Set up

Run the MATLAB software. In the command window type fuzzy and press enter. A new fuzzy logic window will open. Browse and import the required .fis file, press open. Now go to the file section and export the file into the workspace.

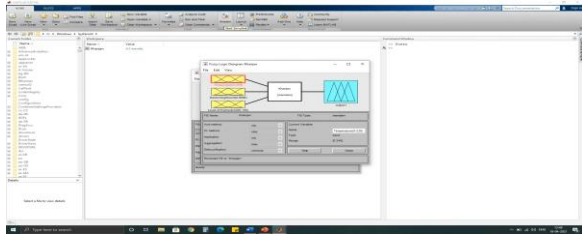

Fig. 1 – Fuzzy Logic Designer

Next, open the Simulink from the MATLAB home page. Browse and import the required .slx file, press open. Within time our framework will be ready to use.[2]

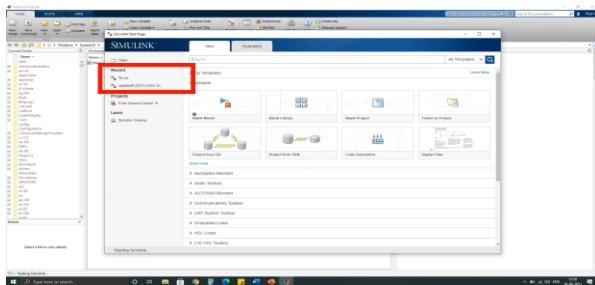

Fig. 2 – Simulink

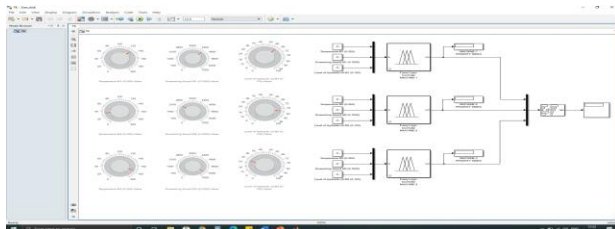

Fig. 3 – System View

2. Inputs

Real-time data of machines such as temperature, screeching sound, and level of hydraulic oil are taken into consideration. For smooth operation, we have provided a significant feature of adding data through rotating knobs.

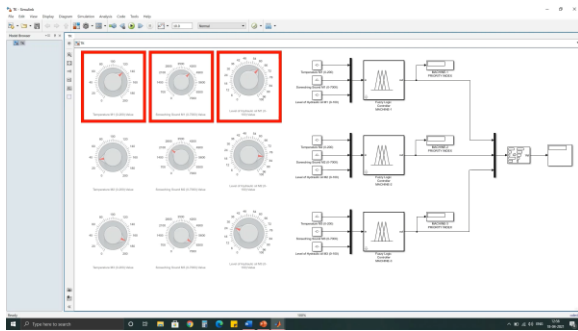

Fig. 4 – Input Parameters

After setting the knob for each machine, we just need to press the run button present on top of the window. Within few seconds priority index for each machine will be displayed on the screen. More the score high is the priority for maintenance.

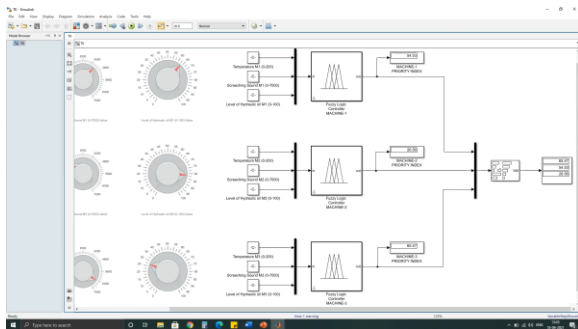

Fig. 5 – Fuzzy Logic of Input Data

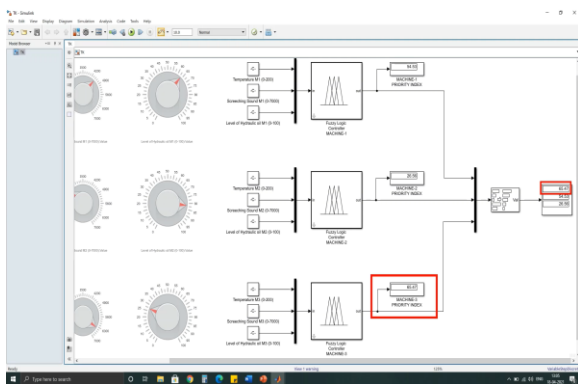

Fig. 6 – Priority Index on Fuzzy Result

IV. Application

	Temperature (°C)	Screeching Sound	Level Of Fluid	Priority Index
Machine 1	60	25%	95%	3
Machine 2	90	80%	35%	1
Machine 3	50	70%	80%	2

Table 1 – Priority Index Calculation

V.RESULT

The desired aim of creating a Priority-based maintenance system using fuzzy logic has been achieved successfully. Hence the system is delivering the proper priority-based results for the planned and unplanned maintenance work. Which maximizes the return on investment under the constrain of budget and time.

VI.CONCLUSION

The purpose of this proposed work is to make such type of system which will help them to get the right information as to what to do and what not to be done for the maintenance work. This system is easy to use and will definitely be playing a sustainable role in the future in the area of maintenance for the industries.

After successfully executing this system, we came to the conclusion that this system can be implemented into the industries for maintenance work which results in maintaining and improving the product quality and life span increasing of machines. This also helps to maintain the economic condition of the industries as most of the fund is invested in maintenance.

VII.REFERENCES

- [1]“Fuzzy Logic with Engineering Applications” by Timothy J Ross.
- [2]Waris, Sehrish & Ahmad, Z.. (2011). APPLICATION OF FUZZY LOGIC IN ACADEMIC SETUP. 10.13140/2.1.3818.2401.
- [3]Mitra, Dipra. (2015). Fuzzy Logic Approach towards Complex Solutions: A Review. International Journal of Computer and Communication Engineering. 4. 2278-5140.
- [4]Castro, Juan. (1999). The limits of fuzzy logic. Mathware & soft computing, ISSN 1134-5632, Vol. 6, N°. 2-3, 1999, pags. 155-161.